

Installation Guide

uPVC Sliding Sash Windows

Measuring

There are mainly two different ways in which the windows will be originally installed; brick to brick or check reveal. Both methods are explained in more detail below.

Brick to Brick

You will see about 20-40mm of visible brick showing on the outside.

How to measure?

Measure between the external brickwork opening and deduct 10mm both in width and height.

Inside



Outside



Check Reveal

The full width of the brick is visible on the outside.

How to measure?

Measure between the external brickwork opening and add 40mm to the width and 20mm* to the height with equal 20mm* sitting behind the brick. (*Providing there is sufficient clearance to do so.)

Inside

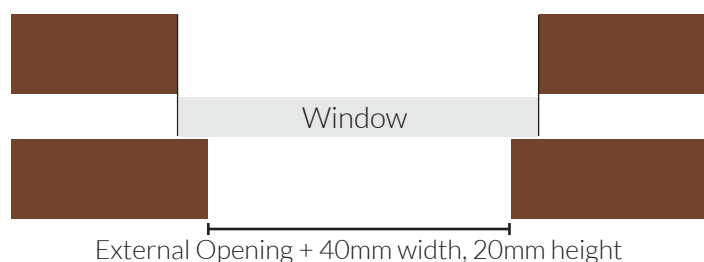

Outside

Important - Check that the internal width and height are larger than external.

Installation Guide

uPVC Sliding Sash Windows

Window Removal

Please read the following steps carefully before attempting to remove any existing windows.



Step 1

Cut the sash cords to the bottom sash, prise off internal staff bead - this enables you to remove the bottom sash.



Step 2

Cut the sash cords to the top sash, prise off the centre parting bead and the top sash can then be removed.



Step 3

Remove the old sash weight as shown.

Installation Guide

uPVC Sliding Sash Windows

Window Removal *continued*



Step 4

Cut the old box near to where you've removed the weights, taking care not to cut or damage any cables that may go through the window.



Step 5

Once you've cut through the box, prise out sides trying not to cause damage to bricks, then remove head rail and cill.



Step 6

Once all the old wooden box has been removed, clean off any old cement or sealant that was around the old windows.

Installation Guide

uPVC Sliding Sash Windows

Installation

The procedures in 8S8213-4 Code of practice for the survey and installation of windows and external doorsets, or any subsequent updates following this manual, should be followed.

Fit the frame into the opening

The frame should be placed into the opening and bedded on a suitable compound, it should be packed under the cill ensuring that it is level, and not bowed. The frame should then be wedged temporarily to hold it in position. Adjust the wedging until the frame is standing vertically, and the jambs are plumb and true from side to side.

Check the diagonal measurements of the frame.

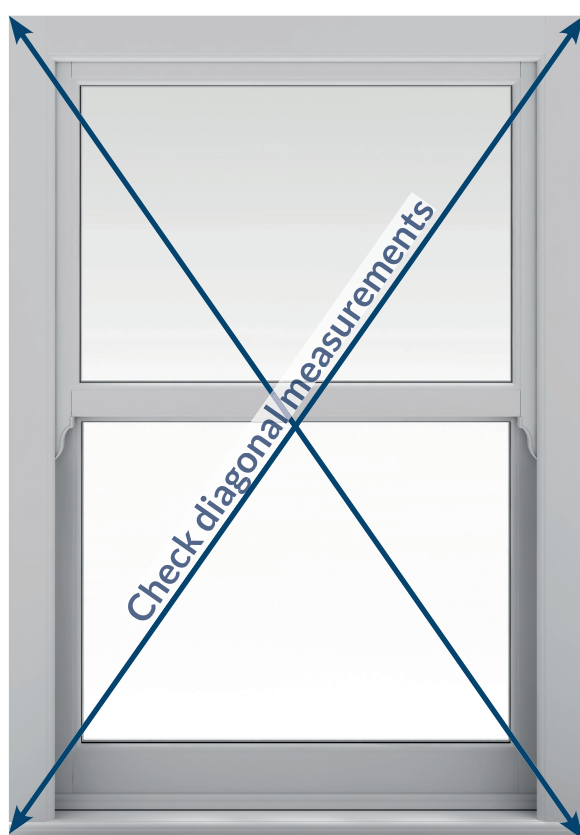

The Frame

Wedge the frame temporarily in the opening ensuring jambs are plum and square.

The Cill

The cill must be level along the opening width, and embedded on a suitable compound.

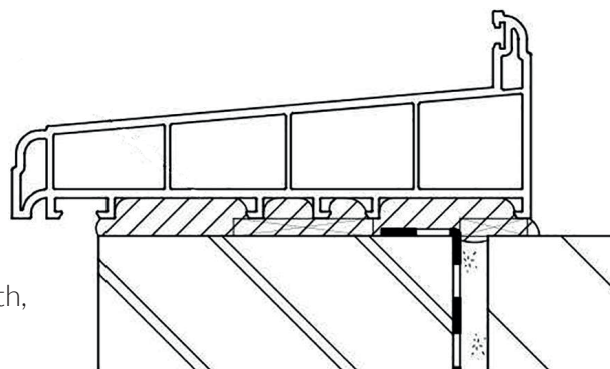

Installation Guide

uPVC Sliding Sash Windows

Installation *continued*

Fixing the frame

The outer frame can be fixed through three positions, page 3 shows details. Fixing should be between 150mm and 250mm from the corners with maximum centres of 600mm.

Before final tightening, the frame should be packed at screw positions with shims. **To ensure optimum weather performance and correct operation of the sashes, the outer frame must not be bowed.** Ensure the gap between the sashes and outer frame is uniform. Check the diagonal measurements of the frame.

Foam fixing should only be used as a gap filler and not an alternative to mechanical fixings. After applying check that the outer frame has not distorted or bowed. Packing pieces can be placed between the frame and the sashes, or a brace put across the frame to prevent bowing.

After installation debris or contaminants should be removed and any drainage paths cleared. Protective tapes should be removed as soon as practical, as ageing of tapes can cause difficulties in removal.

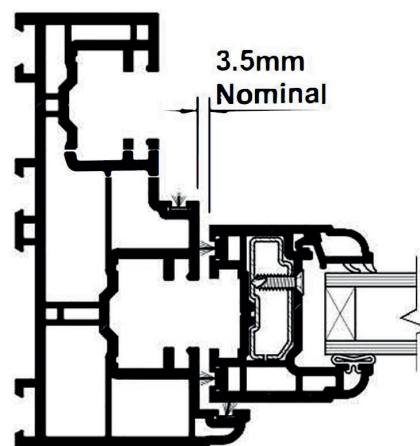
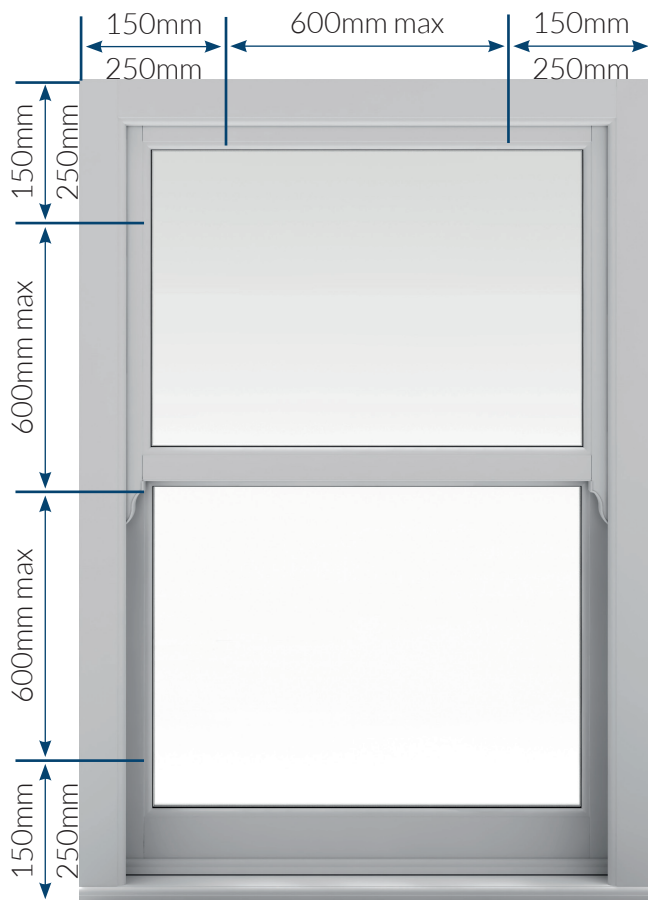

Check gap between both sashes and outer frame.

Installation Guide

uPVC Sliding Sash Windows

Installation *continued*

Fixing Position

As well as the method shown below, frames can also be fixed through the balance channels, but care must be taken not to distort the chamber when tightening the screws. To position a fixing in the top half of the window it will be necessary to remove the balances.

Extreme care should be taken when removing sashes or balances, as they will be under tension and the sash weight will not be supported. (Refer to the balance manufacturer's instructions before removing balances).

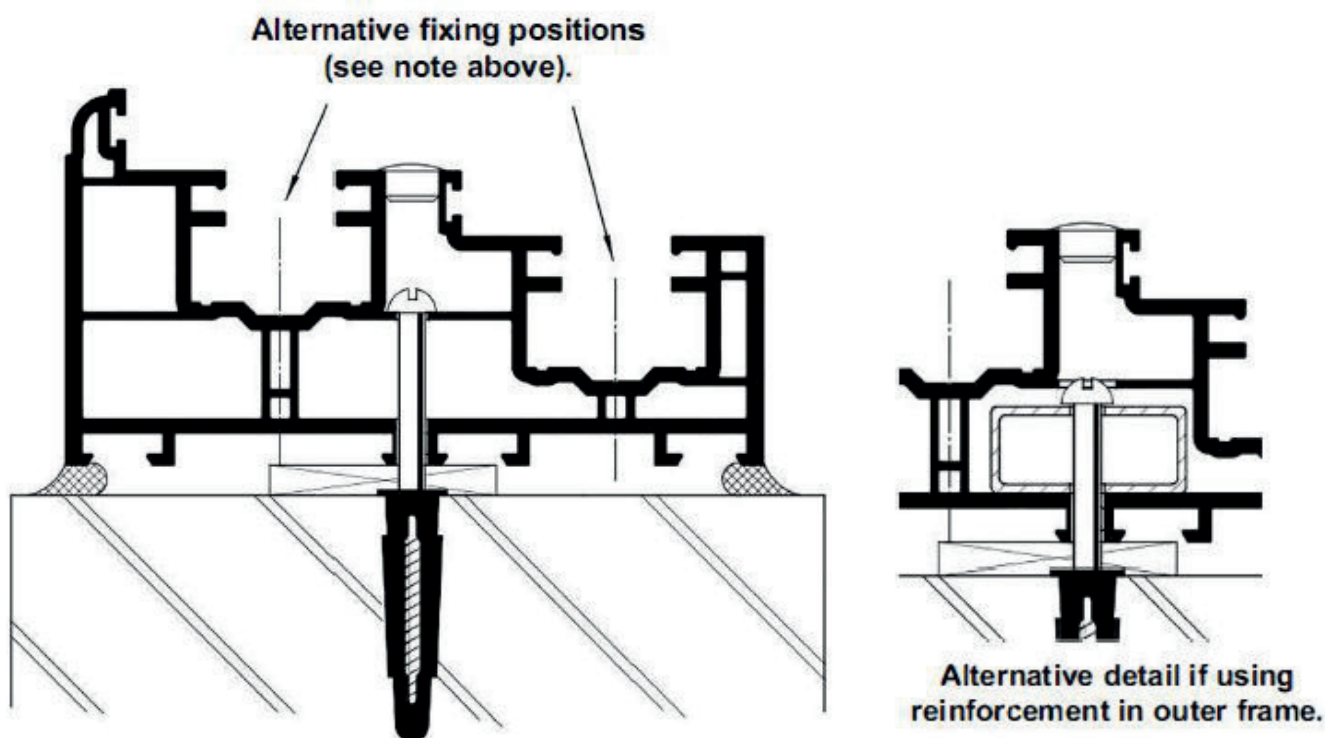

Fixing Lug

There is a 150mm fixing lug (AL01) available. This will twist fix to the outer frame in three different positions to give a choice of fixing hole positions in the protruding part of the lug. Fixing lug spacing should be as through frame fixings.

If using fixing lugs it is important to ensure that the outer frame members are straight & that the window operates correctly. Through fixing may be required, in addition to fixing lugs, to maintain a satisfactory fix for the window.

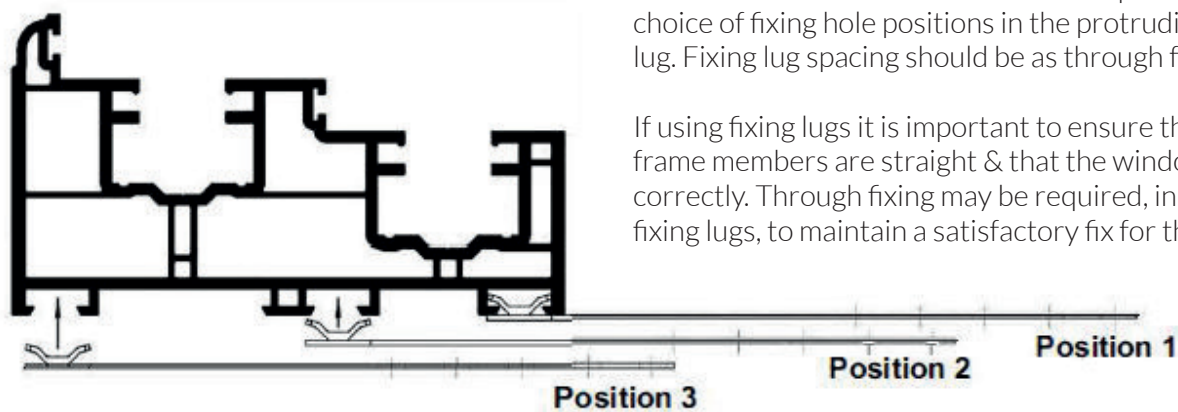

Installation Guide

uPVC Sliding Sash Windows

Installation *continued*

Frame Packers

As an aid to accommodating different installation and building details there are a range of frame packers available. For the outer frame (VS41) and the 150mm Cill (VS42) there are three 63mm wide frame packers and a 19mm wide odd leg add on.

The frame packers are available in 15mm, 30mm and 50mm heights. They can be used in pairs (as shown below) or individually dependant on the building detail. They can be clipped into themselves to achieve alternative sizes.

The odd leg add on is 10mm high and again can be used individually or in combinations. It also clips into itself to accommodate different size requirements.

The 210mm cill (VS14) has a different range range of frame packers. These are 70mm wide and are available in 15mm, 20mm, 35mm and 50mm heights. These can also be clipped into themselves to achieve alternative sizes. The same 10mm odd leg add on is also suitable for use with this cill.

